

# BIRO®

## *Our Equipment Works Harder So You Don't Have To*

The Biro MINI-32 Mini Mixer Grinder makes it easier than ever to break away from the daily grind. Its 50 lb. capacity lets you grind only the amounts you need to keep the case full and still keep your grinds as fresh as possible. Now you can use the same grinder for all of your ground products without having to worry about cross contamination because the MINI-32 is so easy to clean. It's easy to disassemble, and all of the pieces are light so you can just carry all of them to the sink, wash them up, and go on to the next batch. When mounted on its specially designed cart the MINI-32 is ergonomic, so the operator doesn't have to lift a lug over their head or bend over to fill a tray. The 3 hp drive motor gives you the power you need to grind fresh ground meat, sausage, or poultry all day. So break away from the daily grind and keep your ground meat as fresh as possible with the Biro Model MINI-32.



SHOWN WITH OPTIONAL  
EXTRA COST STAND

# MINI-32



*Stands alone for quality  
and value since 1921*

## SPECIFICATIONS

**MODEL** MINI-32 MIXER GRINDER (MINI AUTOMATIC FEED).  
**CONSTRUCTION** STAINLESS STEEL FRAME AND TUB, POLY CARBONATE LID, CAST IRON  
 HOT TIN DIPPED BOWL, RING AND AUGER, SIZE 32.

**MOTORS**

HP	KW	TYPE	VOLTS	AMPS	CYCLE	PHASE	STATUS
3	2.2	DP	208-230/460	11-9.6/4.8	60	3	STD
3	2.2	DP	200	12	60	3	EC

DP=DRIP PROOF    STD=STANDARD    EC=EXTRA COST  
 NC=NO CHARGE    NA=NOT AVAILABLE

**SWITCH** WATERTIGHT MAGNETIC WITH THERMAL OVERLOAD AND UNDER VOLTAGE PROTECTION.  
**POWER CORD** 10' 12-4 CORD WITH 4 PRONG TWIST LOCK 250 VOLT 20A PLUG.  
**CAPACITY** HOPPER: UP TO 50 LBS. (23 KG).  
**GRINDING CAPACITY** UP TO 68 LBS. (31 KG) PER MINUTE.  
**DRIVE SYSTEM** DOUBLE REDUCTION GEAR BOX, BELT/CHAIN.  
**SAFETY** MAGNETIC INTERLOCK ON TUB AND LID.  
**STANDARD** NO INLET (SOLID TUB), REMOVABLE FOR EASIER CLEANING, SPURT GUARD, RING WRENCH, OPERATING AND SAFETY MANUAL.  
**OPTIONS (EC)** SIZE 32 KNIVES AND PLATES, GRINDER STAND WITH LOCKING SWIVEL CASTERS, PNEUMATIC FOOTSWITCH, STAINLESS STEEL CASTERS, 200 VOLT MOTOR.  
**OPTIONS (NC)** NA  
**CERTIFICATION** U.L.  
**WEIGHT** UNCRATED: 480 LBS. (195 KG) APPROXIMATE.  
 CRATED: 611 LBS. (277.7 KG) APPROXIMATE.  
**DIMENSIONS CRATED** L = 48" (122 CM), W = 31" (78.7 CM), H = 60" (152.4 CM)

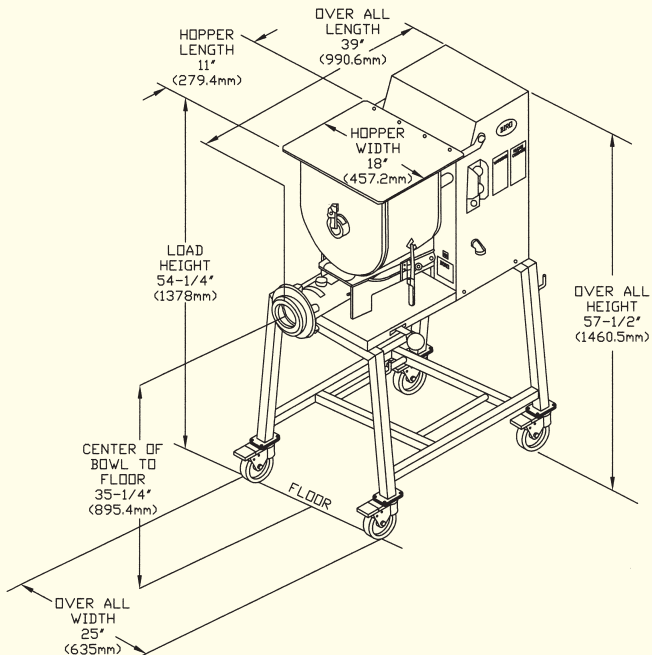

**THE BIRO MANUFACTURING COMPANY**  
 1114 WEST MAIN STREET  
 MARBLEHEAD, OH 43440-2099 U.S.A.  
 Phone: (419) 798-4451  
 Fax: (419) 798-9106  
<http://www.birosaw.com>  
[sales@birosaw.com](mailto:sales@birosaw.com)

All specifications contained herein are subject to change without notification.

ITEM NO.: LIT-MINI-32-298  
 FORM NO.: Md MINI-32-298-10-06-4-MARK

Service is available from over 245 locations worldwide